

Kyland NewPre5100 Modular Controller

Key Features:

- Secure and Manageable
- Compact and Reliable
- Flexible Module Expansion
- High-performance Control
- Extensive Industrial Protocols



Product Specification

NewPre5100		
Computation	CPU	Loongson 2k1000, Dual-core, 1GHz clock frequency
	RAM	2GB. Optional: 4GB
Storage	Standard Storage	256MB
	Storage Expansion	Optional, 128GB, mSATA
	Power Loss Protection	Optional, 128KB.
Control Software Capability	Controller Computation Cycle Redundancy	Configurable, minimum 1ms Support hot standby redundancy controller configuration.
Mechanical Structure	Case	Metal
	Heat Dissipation Method	Passive cooling, fanless
Main Interface	Display Port	1*HDMI
	USB	2*USB2.0
Network Interface	Ethernet	Support 100/1000BASE-T, RJ45. Optional 2 ports, 4 ports
	AUTBUS	Support 1*AUTBUS, optional
Other Communication Interface	Serial Port	Support RS232, RS485, CAN. Optional 2*485+1*232+1*CAN, 1*485+1*232+2*CAN, 4*CAN, 4*485, 2*485+2*CAN
	Wireless Extension	Optional 4G/5G extension
I/O Interface	Local I/O	Optional, support 9*DI+6*DO, 3DO+4*PI+4*PO
	I/O Extension	Support Extension Kyland KYIO modules. Support distributed IO Extension
Power	Input	24VDC (20 ~ 28 VDC), powered by KYPM-DC24
	Output	DC 24VDC, 12VDC, Backplane Bus
	Host Power Consumption	15W

Mechanical Structure	Mechanical Structure	Aluminum Casing
	Ingress Protection Rating	IP40
	Dimensions mm	195 x 100 x 94(W×H×D), contains power supply module
	Overall Weight of the Device	1.7Kg
	Installation Method	Rail installation
Environment	Operating Temperature	-40°C ~ 70°C
	Storage Temperature	-40°C ~ 85°C
	Humidity	5% ~ 95% no condensation
	Heat Dissipation	Fanless
Industry Standard	EMI	FCC CFR47 Part 15, EN55022/CISPR22, Class A
	EMS	IEC 61000-4-2 (ESD), Air: ±8kV; Contact: ±6kV IEC 61000-4-3 (RS), 10V/m (80MHz ~2GHz) IEC 61000-4-4 (EFT), DC Power Port: ±2kV, Singal Port: ±2kV IEC 61000-4-5 (Surge), Power Port: ±1kV/DM, ±2kV/CM, Singal Port: ±1kV (line to line), Singal Port: ±2kV (line to earth), IEC 61000-4-6 (CS), Signal ports: 0.15-80MHz at 10V/m, Power ports: 0.15-80MHz at 10V/m
	Mechanical	IEC60068-2-6(vibration) IEC60068-2-27(shock) IEC60068-2-32(free fall)

Product Selection Guide

Models	Description
NewPre5100-L2K1-M2D0W4-0403C1A	Loongson 2k1000- RAM 4G-256KB Ferroelectric - Hard Drive 128G+256M- Support 4G-4 Ethernet Ports -ICAN-IRS232-2RS485(Equipped with H-Type IO and Power Supply)
NewPre5100-L2K1-M1D2MWOA-0200A	Loongson 2k1000- RAM 2G-256KB Ferroelectric -256M Onboard Storage -AUTBUS-2 Ethernet Ports (Equipped with H-Type IO and Power Supply)
NewPre5100-L2K1-M1D0W0-0402C2B	Loongson 2K1000-2G RAM -128G Hard Drive -4 Ethernet Ports -2CAN2RS485(Equipped with C -Type IO and Power Supply)

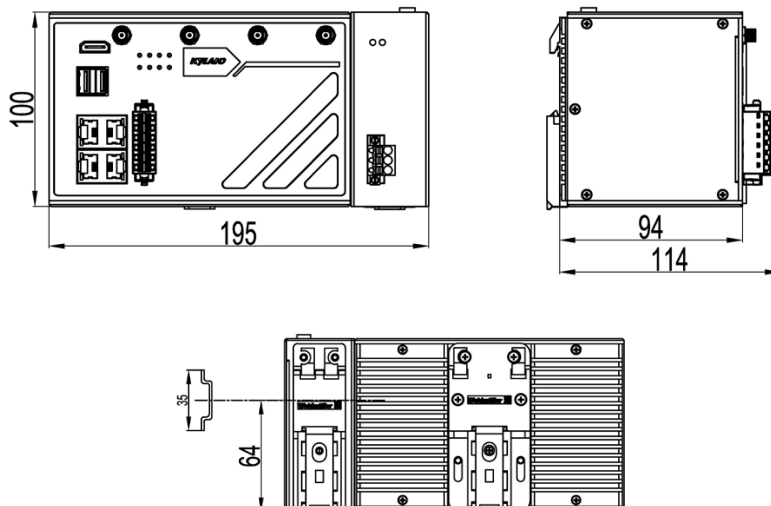

Product details:

