

Opal5L/Opal8L Series Entry-Level Industrial Ethernet Switch Hardware Installation Manual

Publication Date: Apr. 2023

Version: V1.1

No.: 112020243

KYLAND

Certificate of Compliance

EU Directive 2011/65/EU (RoHS-Directive)

Dear Ladies and Gentlemen,

According to the EU Directive 2011/65/EU the use of several substances for electrical and electronic equipment in defined categories is restricted. Kyland hereby declares that the parts used in our products are produced in full compliance with the Directive 2011/65/EU “Restriction of the Use of Certain Hazardous Substances in Electrical and Electronic Equipment” (RoHS), including all amendments to the EU-directive (e.g. The Restrictions of DecaBDE).

This information and our technical advice – whether verbal, in writing or by way of trials – are given in good faith and to the best of our knowledge but without liability and warranty, unless law admits the liability or warranty. This also applies where proprietary rights of third parties are involved. Our advice does not release you from the obligation to check its validity and to test our products as to their suitability for the intended processes and applications. The application, use and processing of our products and the products manufactured by you on the basis of our technical advice are beyond our control and, therefore, entirely your own responsibility. Our products are sold in accordance with the current version of our General Conditions of Sale and Delivery.

Disclaimer: Kyland Technology Co., Ltd. tries to keep the content of this manual as accurate and as updated as possible. This document is not guaranteed to be error-free, and we reserve the right to amend it without notice to users.

All rights reserved.

No part of this documentation may be excerpted, reproduced, translated, annotated or duplicated, in any form or by any means without the prior written permission of Kyland Corporation.

Copyright © 2023 Kyland Technology Co., Ltd.

Notice for Safety Operation

The product performs reliably as long as it is used according to the guidance. Artificial damage or destruction of the device should be avoided. Before using the device, read this notice carefully for personal and equipment safety. Please keep the manual for further reference. If the device used not according to the specified way by Kyland, the protection provided by the device maybe diminished. And Kyland is not liable to any personal or equipment damage caused by violation of this notice.

- Ensure the area where the device is used is clean and dry. Keep the ambient relative humidity within the range from 5% to 95% (non-condensing).Be suitable for indoor use.
- Do not place the device in an environment with high magnetic field, strong shock, or high temperature. Keep the working and storage temperatures within the allowed range.
- Install and place the device securely and firmly.
- Please keep the device clean; if necessary, wipe it with a soft cotton cloth.
- Do not place any irrelevant materials on the device or cables. Ensure adequate heat dissipation and tidy cable layout without being entangled or knotted.
- Wear antistatic gloves or take other protective measures when operating the device.
- Avoid any exposed metal wires because they may be oxidized or electrified.
- Install the device in accordance with related national and local regulations.
- Before power-on, make sure the power supply is within the allowed range of the device. High voltage may damage the device.
- Power connectors and other connectors should be firmly interconnected.
- Do not plug in or out the power supply with wet hands. When the device is powered on, do not touch the device or any parts with wet hands.
- Before operating a device connected to a power cable, remove all jewelry (such as rings, bracelets, watches, and necklaces) or any other metal objects, because they may cause electric shock, burns, or welding.
- Do not operate the device or connect or disconnect cables during an electrical storm.
- Use compatible connectors and cables. If you are not sure, contact our sales or

technical support personnel for confirmation.

- Do not disassemble the device by yourself. When an anomaly occurs, contact our sales or technical support personnel.
- If any part is lost, contact our sales or technical support personnel to purchase a replacement. Do not purchase parts from other channels.
- Dispose of the device in accordance with relevant national provisions, preventing environmental pollution.

In the following cases, please immediately shut down your power supply and contact your Kyland representative:

- Water gets into the equipment.
- Equipment damage or shell damage.
- Equipment operation or performance has abnormally changed.
- The equipment emits odor, smoke or abnormal noise.

Note: The security of any system merged with this device is the responsibility of the assembler.

The following information applies when operating this device in hazardous locations:

Suitable for use in Class I, Division 2, Groups A, B, C and D Hazardous Locations, or nonhazardous locations only.

Cet appareillage est utilisable dans les emplacements de Classe I, Division 2, Groupes A, B, C et D, ou dans les emplacements non dangereux seulement.

WARNING: EXPLOSION HAZARD

- Do not disconnect equipment while the circuit is live or unless the area is known to be free of ignitable concentrations.
- Substitution of any component may impair suitability for Class I, Division 2.

AVERTISSEMENT: RISQUE D'EXPLOSION

- Avant de deconnecter l'equipement, couper le courant ou s'assurer que l'emplacement est designe non dangereux.
- La substitution de composants peut rendre ce materiel inacceptable pour les

emplacements de Classe I, Division 2.

NOTE: This equipment has been tested and found to comply with the limits for a Class A digital device, pursuant to part 15 of the FCC Rules. These limits are designed to provide reasonable protection against harmful interference when the equipment is operated in a commercial environment. This equipment generates, uses, and can radiate radio frequency energy and, if not installed and used in accordance with the instruction manual, may cause harmful interference to radio communications. Operation of this equipment in a residential area is likely to cause harmful interference in which case the user will be required to correct the interference at his own expense.

If the equipment is used in a manner not specified by Company Name, the protection provided by the equipment may be impaired.

Contents

1 Product Overview	1
2 Structure and Interface	3
2.1 Front Panel	3
2.2 Top Panel.....	4
3 Mounting.....	6
3.1 Dimension Drawing.....	6
3.2 Mounting Modes and Steps	8
3.2.1 DIN-Rail Mounting	9
3.2.2 DIN-Rail Dismounting	10
4 Connection	12
4.1 10/100Base-T(X) Ethernet Port.....	12
4.2 100Base-X SFP Slot	13
4.3 Grounding	15
4.4 Power Terminal Block	15
5 LEDs.....	18
6 Basic Features and Specifications.....	19

1 Product Overview

Opal5L/Opal8L industrial Ethernet switches are specially designed for industrial control applications.

Opal5L/Opal8L supports normal-temperature-range and wide-temperature-range models.

Opal5L provides five 10/100Base-T(X) Ethernet ports or one 100Base-X SFP slots, four 10/100Base-T(X) ports; Opal8L provides eight 10/100Base-T(X) Ethernet ports or two 100Base-X SFP slots, six 10/100Base-T(X) ports, For details, see the following table.

Table 1 Opal5L Models

Models	Opal5L-Ports-Connector-PS1-PS2 Opal5L-E-Ports-Connector-PS1-PS2
Code definition	Code option
E	E: Normal temperature range models, ambient temperature: $-10^{\circ}\text{C} \leq T_{amb} \leq +60^{\circ}\text{C}$ N/A: Wide temperature range models, ambient temperature: $-40^{\circ}\text{C} \leq T_{amb} \leq +75^{\circ}\text{C}$
Ports: S/M, T	5T=five 10/100Base-T(X) ports 1SFP4T=one 100Base-X SFP slots; four 10/100Base-T(X) ports
PS1-PS2: power input	LV-LV=24VAC/DC (18-30VAC, 50/60Hz; 12-48VDC), redundant power input)

Table 2 Opal8L Models

Model	Opal8L-Ports-Connector-PS1-PS2 Opal8L-E-Ports-Connector-PS1-PS2
Code definition	Code option
E	E: Normal temperature range models, ambient temperature: $-10^{\circ}\text{C} \leq T_{amb} \leq +60^{\circ}\text{C}$ N/A: Wide temperature range models, ambient temperature: $-40^{\circ}\text{C} \leq T_{amb} \leq +75^{\circ}\text{C}$
Ports: S/M, T	8T= eight 10/100Base-T(X) ports 2SFP6T=two 100Base-X SFP slots; six 10/100Base-T(X) ports

PS1-PS2: power input	LV-LV=24VAC/DC (18-30VAC, 50/60Hz; 12-48VDC), redundant power input)
----------------------	--

**Note:**

We reserve the right to amend the product information listed in this table without notice. To obtain the latest information, you can contact our sales or technical support personnel.

2 Structure and Interface



Caution:

It is recommended to purchase the port dustproof shield (optional) to keep ports clean and ensure switch performance.

2.1 Front Panel

- Opal5L Front Panel

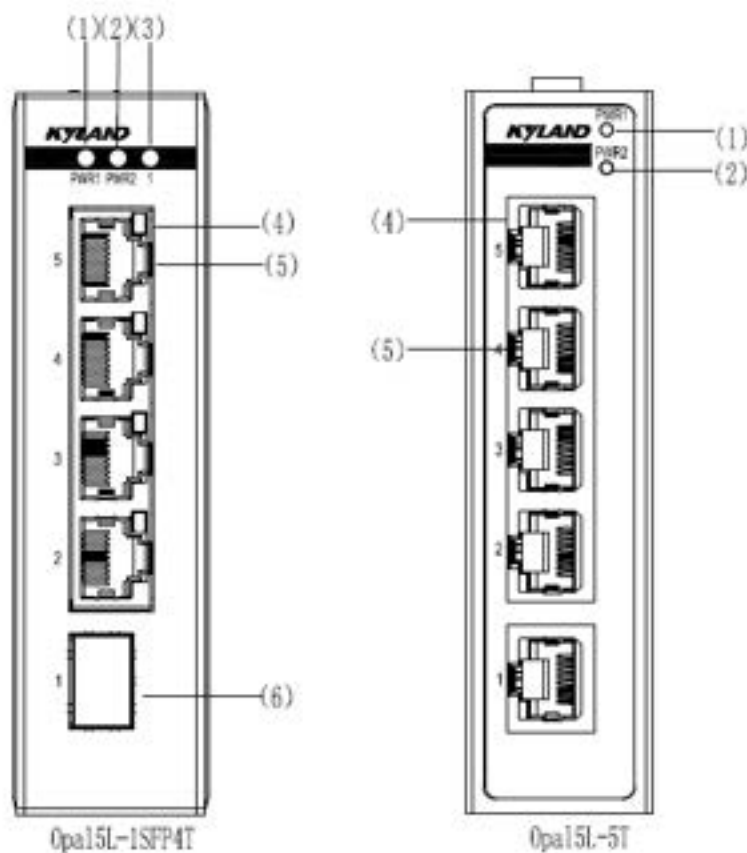

Figure 1 Opal5L Front Panel

- (1) Power 1 LED
- (2) Power 2 LED
- (3) 100M SFP interface indicator
- (4) 10/100Base-X SFP Port connection status LED (green)
- (5) 10/100Base-T(X) Ethernet Port
- (6) 100M SFP Slot

- Opal8L Front Panel

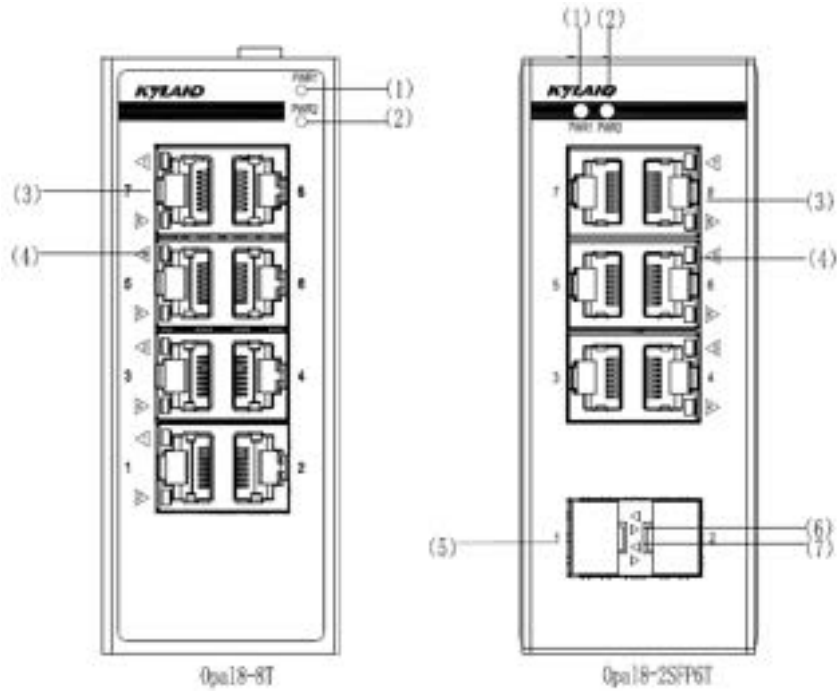

Figure 2 Opal8L Front Panel

- (1) Power 1 LED
- (2) Power 2 LED
- (3) 10/100Base-T(X) Ethernet Port
- (4) 10/100Base-T(X) Ethernet Port connection status LED (green)
- (5) 100Base-X SFP slot
- (6) 10/100Base-X Port connection status LED (green)
- (7) 10/100Base-X Port connection status LED (green)

2.2 Top Panel

- Opal5L Top Panel

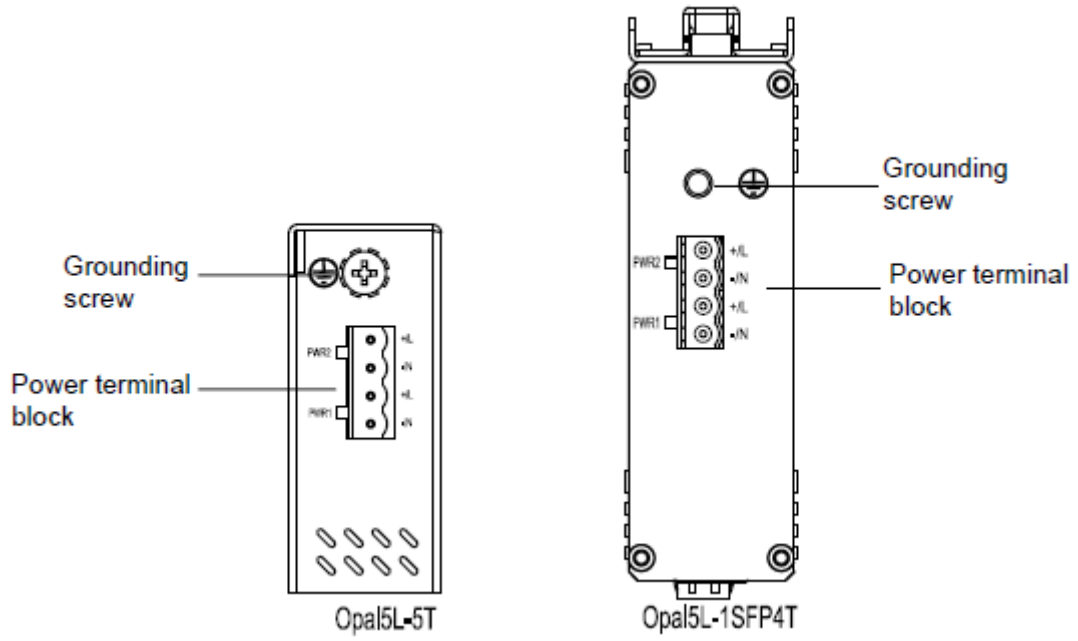

Figure 3 Opal5L Top Panel

- Opal8L Top Panel

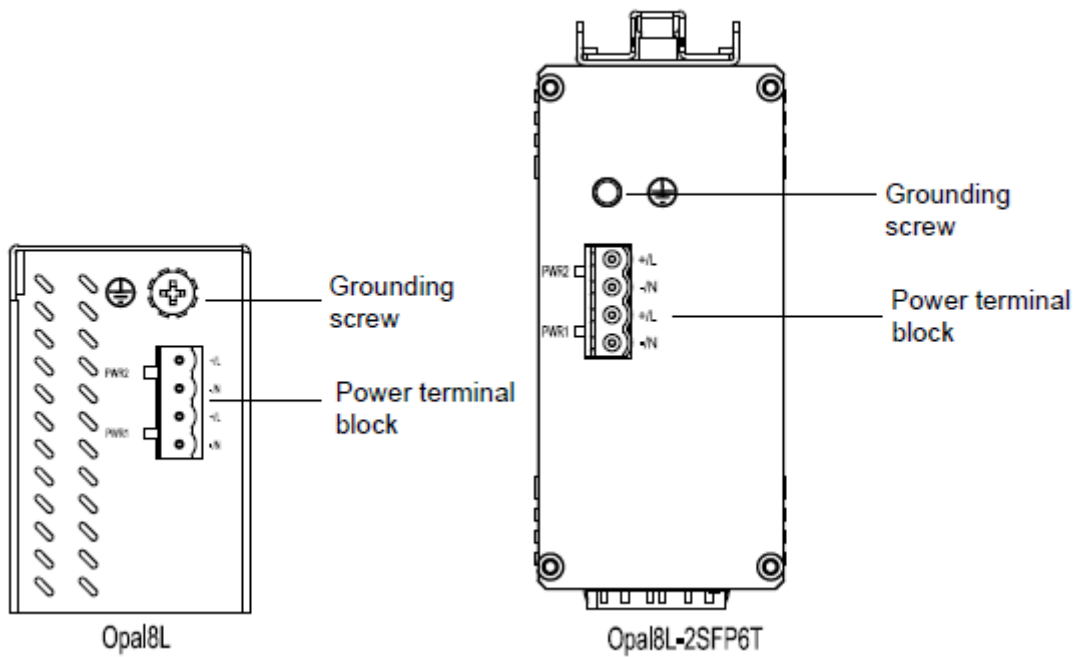

Figure 4 Opal8L Top Panel

3 Mounting

3.1 Dimension Drawing

- Opal5L-5T

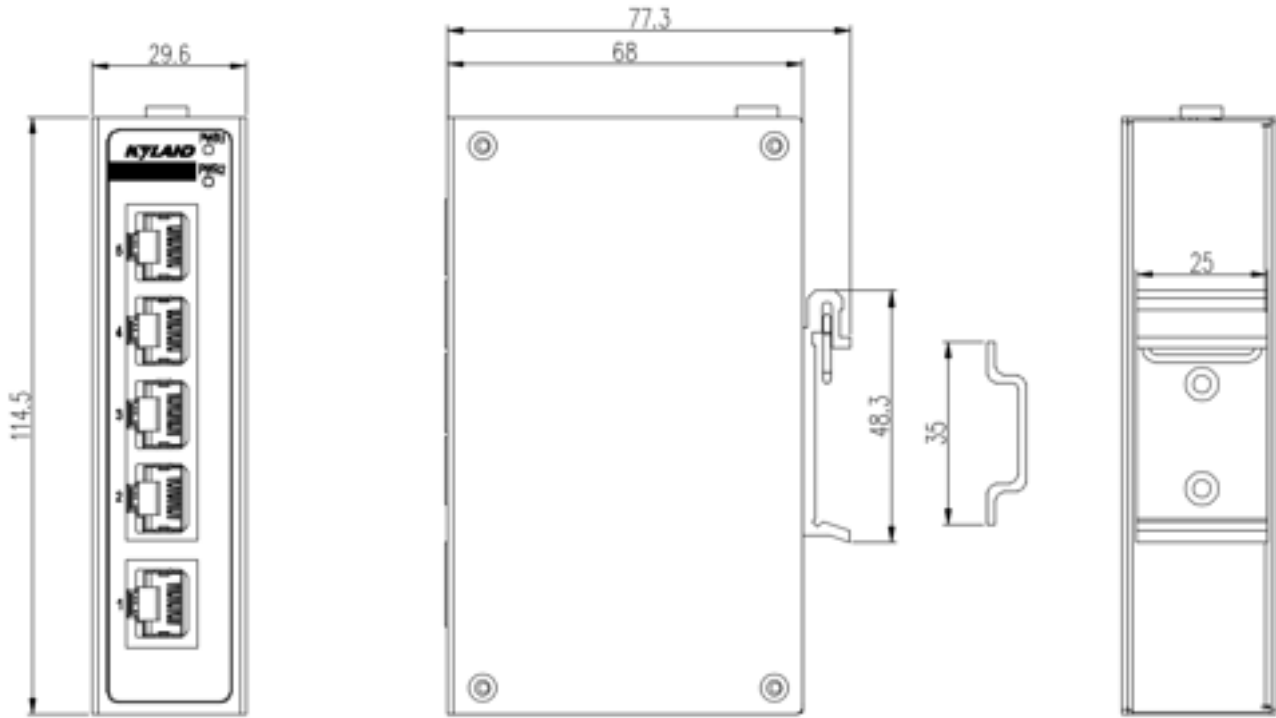

Figure 5 Opal5L-5T Dimensions for DIN-Rail Mounting (unit: mm)

- Opal5L-1SFP4T

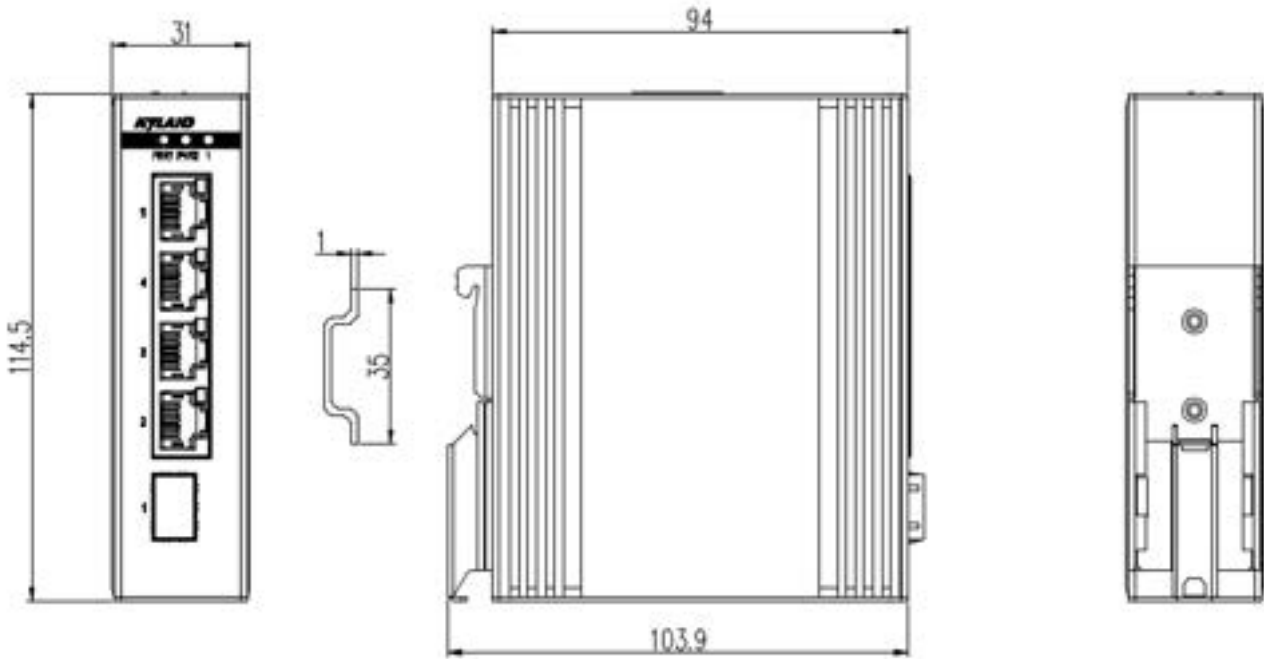

Figure 6 Opal5L-1SFP4T Dimensions for DIN-Rail Mounting (unit: mm)

- Opal8L-8T

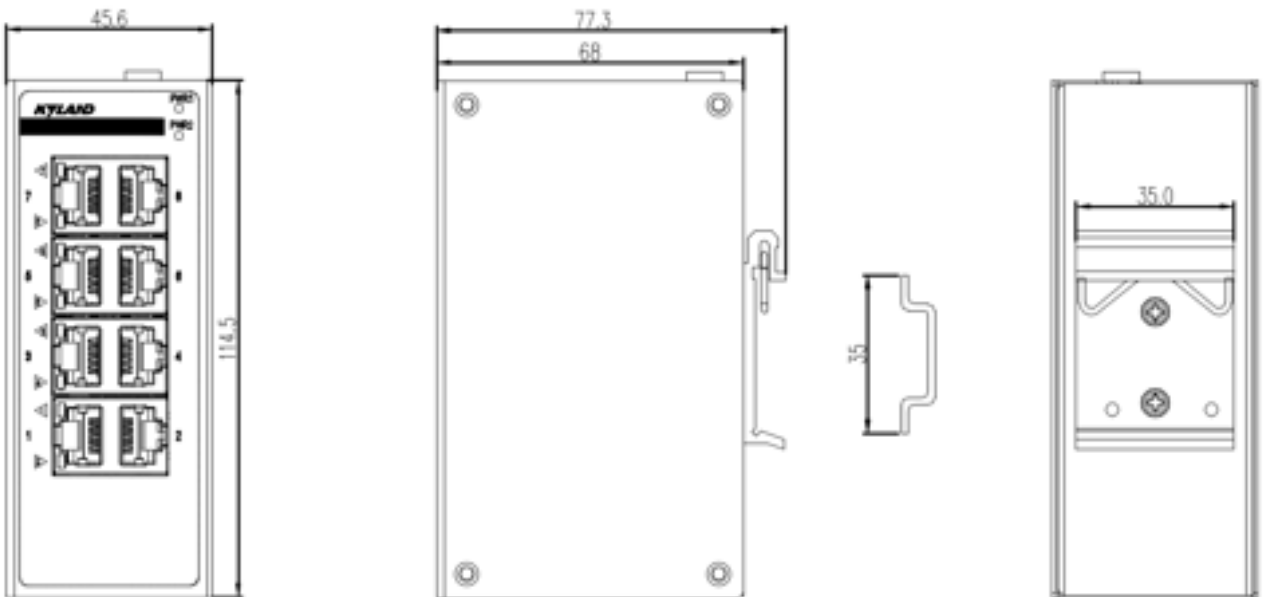

Figure 7 Opal8L-8T Dimensions for DIN-Rail Mounting (unit: mm)

- Opal8L-2SFP6T

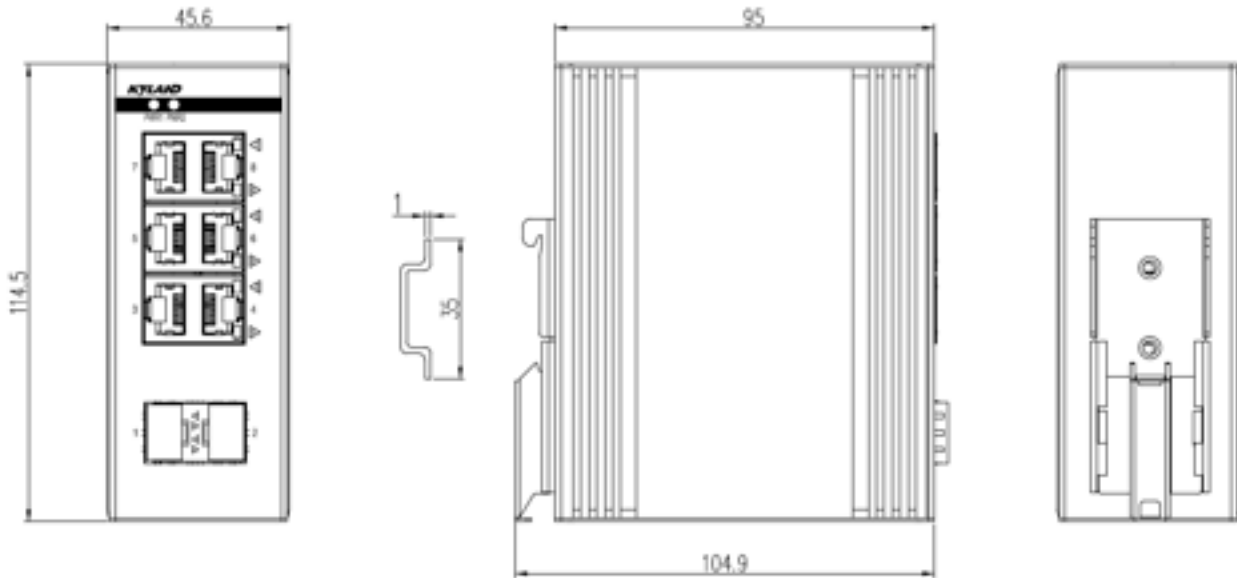

Figure 8 Opal8L-2SFP6T Dimensions for DIN-Rail Mounting (unit: mm)



Caution:

- As part of the heat dissipation system, the switch housing becomes hot during operation. Please use caution when coming in contact and avoid covering the switch housing when the switch is running.
- The figures in this manual are only for reference.

3.2 Mounting Modes and Steps

The device supports DIN-rail mounting. Before installation, make sure that the following requirements are met.



Note:

- Devices are to be installed in an ATEX /IECEX Certified IP54 enclosure and accessible only by the use of a tool.
- Devices are for use in an area of not more than pollution degree 2 in accordance with IEC 60664-1.
- Customer shall insure device working in the right ambient temperature, $-10^{\circ}\text{C} \leq T_{amb} \leq +60^{\circ}\text{C}$ for Opal5L-E & Opal8L-E series and $-40^{\circ}\text{C} \leq T_{amb} \leq +75^{\circ}\text{C}$ for Opal5L & Opal8L series.

- No direct sunlight, distant from heat source and areas with strong electromagnetic interference.

3.2.1 DIN-Rail Mounting

Step 1: Select the mounting position for the device and guarantee adequate space and heat dissipation.

Step 2: Insert the connecting seat onto the top of the DIN rail, and push the bottom of the device inward and upward to ensure the DIN rail fits in the connecting seat. Make sure the device is firmly installed on the DIN rail, as shown in the following figure.

- Opal5L-5T、Opal8L-8T DIN-Rail Mounting

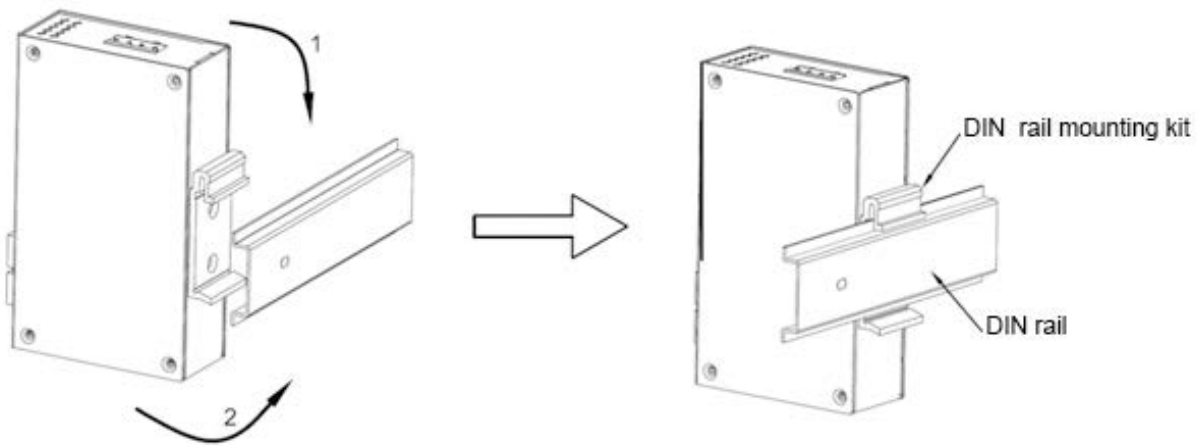

Figure 9 Opal5L-5T、Opal8L-8T DIN-Rail Mounting

- Opal5L-1SFP4T、Opal8L-2SFP6T DIN-Rail Mounting

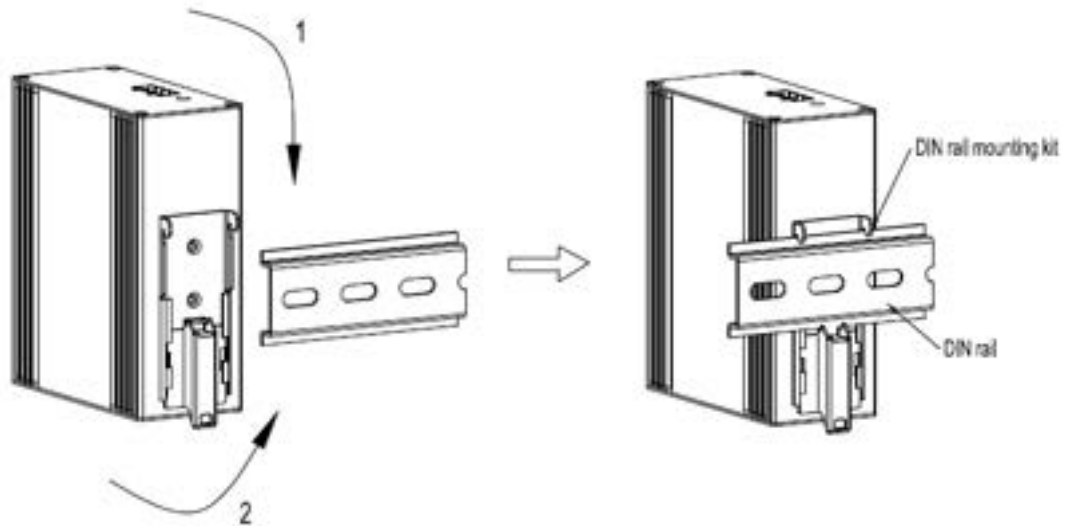

Figure 10 Opal5L-1SFP4T、Opal8L-2SFP6T DIN-Rail Mounting

3.2.2 DIN-Rail Dismounting

Step 1: As shown in the following figure, press the device downward and move the device in direction 1 until the bottom of the device is detached from the DIN rail.

Step 2: Pull the device upward and move the device in direction 2 until the device is removed from the DIN rail completely.

- Opal5L-5T、Opal8L-8T DIN Rail Dismounting

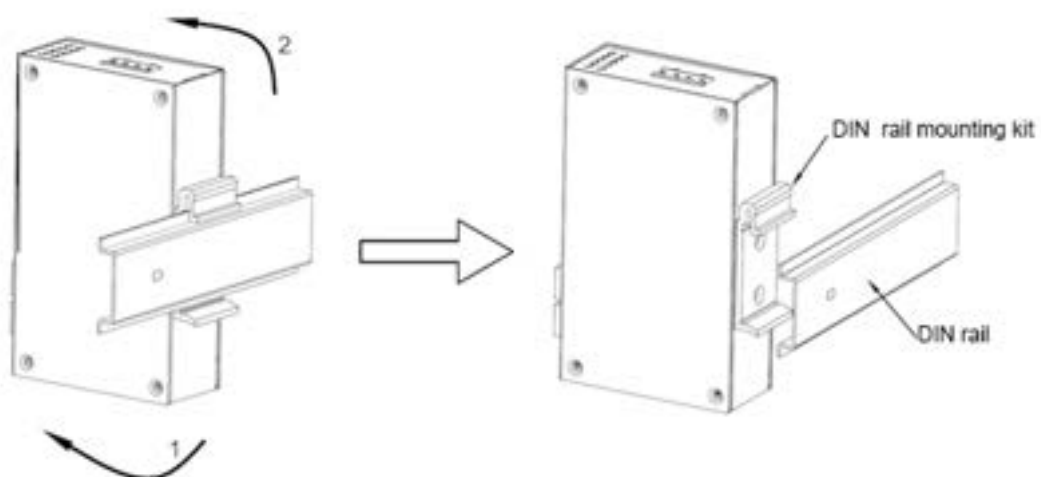

Figure 11 Opal5L-5T、Opal8L-8T DIN Rail Dismounting

- Opal5L-1SFP4T、Opal8L-2SFP6T DIN Rail Dismounting

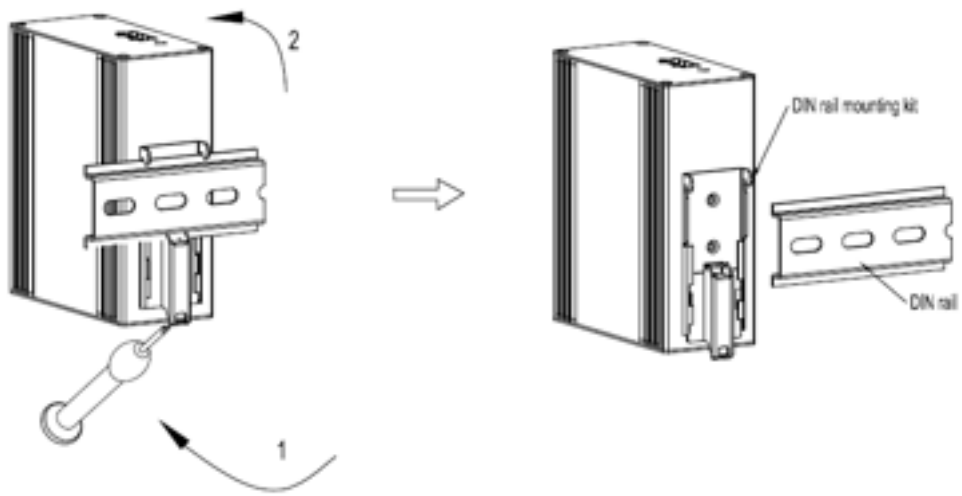

Figure 12 Opal5L-1SFP4T、Opal8L-2SFP6T DIN Rail Dismounting

4 Connection

4.1 10/100Base-T(X) Ethernet Port

10/100Base-T(X) Ethernet port is equipped with RJ45 connector. The port is self-adaptive. It can automatically configure itself to work in 10M or 100M state, full or half duplex mode. The port can also adapt to MDI or MDI-X connection automatically. You can connect the port to a terminal or network device with a straight-through or cross-over cable.

- Pin Definition

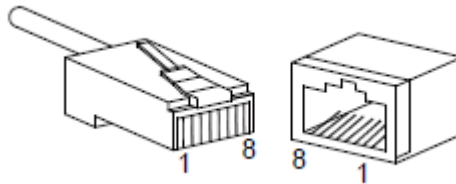

Figure 13 RJ45 Port

Table 3 Pin Definitions of 10/100Base-T(X) RJ45 Port

Pin	MDI-X Signal	MDI Signal
1	Receive Data+ (RD+)	Transmit Data+ (TD+)
2	Receive Data- (RD-)	Transmit Data- (TD-)
3	Transmit Data+ (TD+)	Receive Data+ (RD+)
6	Transmit Data- (TD-)	Receive Data- (RD-)
4, 5, 7, 8	Unused	Unused



Note:

"+" and "-" indicate level polarities.

- Wiring Sequence

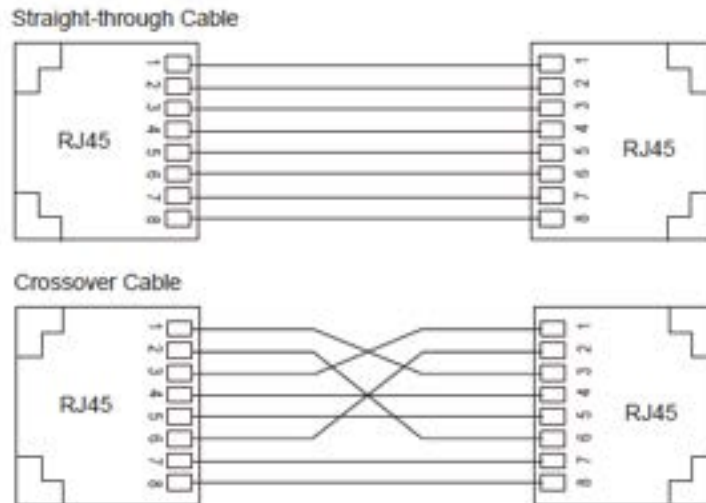

Figure 14 Connection Using Straight-through/Cross-over Cable



Note:

The color of the cable for RJ45 connector meets the 568B standard: 1-orange and white, 2-orange, 3-green and white, 4-blue, 5-blue and white, 6-green, 7-brown and white, and 8-brown.

4.2 100Base-X SFP Slot

100Base-X SFP slot: You can enable data transmission only after inserting an SFP optical module into the slot and connecting cable properly. The following table lists the SFP optical modules (optional) supported by the switch.

Table 1 SFP Optical Modules for 100Base-X SFP slot

Model	Interface	MM /SM	Connector	Center Wavelength (CWL)	Transmission Distance
IFSFP-M-LX-LC-1310-2	100Base-FX port	MM	LC	1310nm	2km
IFSFP-S-LH-LC-1310-40	100Base-FX port	SM	LC	1310nm	40km

100M SFP Optical Module

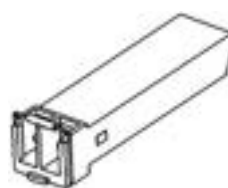

Figure 15 100M SFP Optical Module

100M SFP optical module is equipped with LC connector, and each port consists of a TX (transmit) port and an RX (receive) port. To enable communication between Device A and Device B, connect the TX (transmit) port of Device A to the RX (receive) port of Device B, and the RX (receive) port of Device A to the TX (transmit) port of Device B. The following figure shows the cable connection of the 100M SFP optical module.



Figure 16 Cable Connection of 100M SFP Optical Module

● How to Connect the SFP Optical Module

Insert the SFP optical module into the SFP slot in the switch, and then plug the optical fiber into the TX port and RX port of the SFP module.

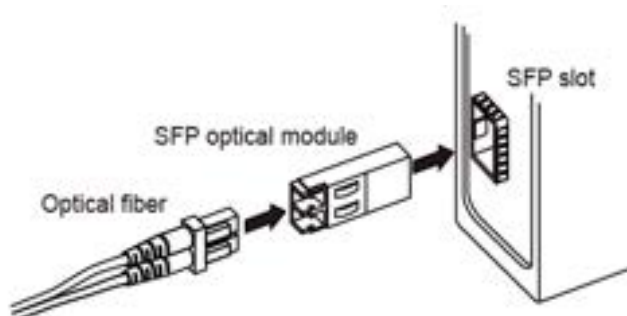

Figure 17 Connecting the 100M SFP Optical Module

How to Determine the RX Port and TX Port of 100M SFP Optical Module

1. Insert the two connectors in one end of optical fiber into the 100M SFP module, and those in the other end of the optical fiber into the SFP module of another switch.
2. View the corresponding port connection status LED in the front panel: If the LED blinks, the link is connected. If the LED is off, the link is not connected. This may be caused by incorrect connection of the TX and RX ports. In this case, swap the two connectors in the one end of the optical fiber.

Caution:



- The device uses laser to transmit signals in fibers. The laser meets the requirements of level 1 laser products. Routine operation is not harmful to your eyes, but do not look directly at the fiber port when the device is powered on.
- If the defined transmission distance of an SFP module is longer than 60km, do not use a short fiber (<20km) for connection. If such a short fiber is used, the module will be burned.

4.3 Grounding

Grounding protects the device from lightning and interference. Therefore, you must ground the device properly. You need to ground the device before it is powered on and disconnect the grounding cable after the device is powered off.

There is a grounding screw (see Figure 3、 Figure 4) on the top panel of the switch. The screw is for chassis grounding. After crimping one end of the grounding cable to a cold pressed terminal, secure the end of the grounding cable to the grounding screw and firmly connect the other end to ground.



Note:

Cross-sectional area of the chassis grounding cable > 2.5mm²; Grounding resistance < 5Ω.

4.4 Power Terminal Block

There is a power terminal block on the top panel of the device. You need to connect the power wires to the terminal block to provide power for the device. The switch supports redundant power supply with 4-pin 5.08mm-spacing plug-in terminal block. When one power input is faulty, the switch can continue operating properly, thereby improving network reliability



Note:

- Others: Suitable cable with temperature of 85.5°C at least must be used for the power input terminal.
- All field wiring intended for connection to the power terminal shall consist of copper conductors with the insulation locally removed. Additional intermediate connecting parts, other

than ferrules, shall not be used.

- 4-Pin 5.08mm-Spacing Plug-in Terminal Block

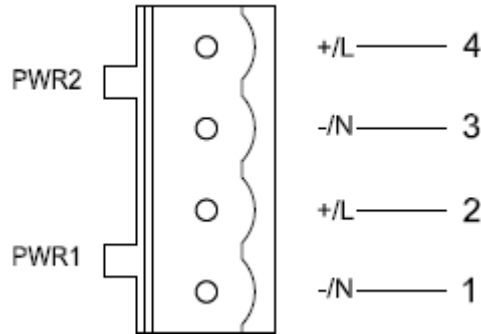

Figure 18 4-Pin 5.08mm-Spacing Plug-in Terminal Block (socket)

Table 4 Pin Definitions of 4-Pin 5.08mm-Spacing Plug-in Terminal Block

Pin Number	DC Wiring Definition	AC Wiring Definition
1	PWR1: -	PWR1: N
2	PWR1: +	PWR1: L
3	PWR2: -	PWR2: N
4	PWR2: +	PWR2: L

- Wiring and Mounting

Step 1: Ground the device properly according to section 4.2.

Step 2: Remove the power terminal block from the device.

Step 3: Insert the power wires into the power terminal block according to Table 4 and secure the wires.

Step 4: Insert the terminal block with the connected wires into the terminal block socket on the device.

Step 5: Connect one end of the power cable to an external power supply system (with the allowed power range). If the power LED on the front panel of the switch turns on, the power supply is connected properly.

Wiring and mounting should meet following specifications.

Table 5 Wiring and Mounting Specifications

Terminal Type	Required Torque	Wire Range (AWG)
Terminal Block Plug	4.5-5.0 lb-in (BLZ 5.08) & 4.4 lb-in (BLZP 5.08HC) for WEIDMUELLER terminal block	12-26
Terminal Block Plug	4.4 (M2.5) /6.0 (M3.0) lb-in for Degson terminal block	12-28
Terminal Block Plug	6.2 lb-in (TLPS(@21)) for Tianli terminal block	12-30
Terminal Block Plug	3.6 lb-in KF222 (@28)(#1) for kaifeng	12-28



Caution:

- Provision shall be made to prevent the rated voltage from being exceeded by transient disturbances of more than 140% of the rated voltage.
- Power adapter provide by end customer shall be non-sparking.
- Before connecting the device to power supply, make sure that the power input meets the power requirement. If connected to an incorrect power input, the device may be damaged.
- To comply with UL restrictions, this equipment must be powered from a source compliant with SELV.



Warning:

- Do not touch any exposed conducting wire, terminal, or component with a voltage warning sign, because it may cause personal injury.
- Do not remove any part or plug in or out any connector when the device is powered on.

5 LEDs

Table 6 LEDs

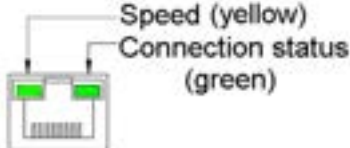
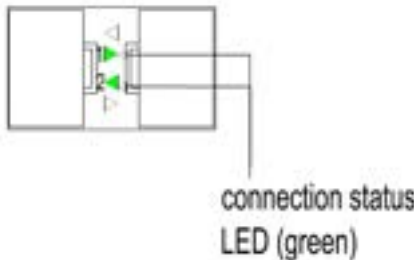
LED	State	Description
Power 1 LED	On	The power 1 is connected and operates properly.
	Off	The power 1 is not connected or operates abnormally.
Power 2 LED	On	The power 2 is connected and operates properly.
	Off	The power 2 is not connected or operates abnormally.
		
10/100Base-T(X) Ethernet port connection status LED (green)	On	Effective port connection
	Blinking	Ongoing network activities
	Off	No effective port connection
		
100Base-X SFP slot connection status LED (green)	On	Effective port connection
	Blinking	Ongoing network activities
	Off	No effective port connection

6 Basic Features and Specifications

Power Supply		
Power Identifier	Range	
LV	24VAC/DC(18-30VAC, 50/60Hz; 12-48VDC)	
Terminal Block	4-Pin 5.08mm-Spacing Plug-in Terminal Block	
Rated Power Consumption		
Rated Power Consumption	Opal5-5T < 2.0W (MAX) Opal5-1SFP4T < 2.4W (MAX) Opal8-8T < 2.2W (MAX) Opal8-2SFP6T < 3.4 W (MAX)	
Physical Characteristics		
Housing	Metal, fanless	
Protection Class	IP30	
Installation	DIN-Rail Mounting	
Dimensions(WxHxD)	Opal5-5T: 29.6mm×114.5mm×68mm Opal5-1SFP4T: 31mm×114.5mm×94mm Opal8-8T: 45.6mm×114.5mm×68mm Opal8-2SFP6T: 45.6mm×114.5mm×95mm (excluding connectors, DIN rail)	
Weight	Opal5-5T < 0.2Kg Opal5-1SFP4T < 0.3Kg Opal8-8T < 0.3Kg Opal8-2SFP6T < 0.35Kg	
Environmental Limits		
Applicable Environmental	Indoor	
Ambient Temperature	-10°C ≤ Tamb ≤ 60°C	Opal5L-E series, Opal8L-E series

	$-40^{\circ}\text{C} \leq T_{\text{amb}} \leq 75^{\circ}\text{C}$	Opal5L series, Opal8L series
Storage Temperature	$-40^{\circ}\text{C} \sim +85^{\circ}\text{C}$	
Ambient Relative Humidity	5%~95% (no condensing)	
Pollution degree	2	
Altitude	2000m	
MTBF		
MTBF	Opal5-5T:5777888h Opal5-1SFP4T:8502760h Opal8-8T:6106558h Opal8-2SFP6T:8301541h	
Warranty		
Warranty	Five years	

KYLAND

Kyland Technology Co., Ltd.

No.901 Floor 8,Building No.2,Shixing
Avenue 30#,Shijingshan District,Beijing,

【100041 China】

FAX: +86-10-88796678

Website: <http://www.kyland.com>

Email: support@kyland.com

For more information about KYLAND products,
please visit our website:

<http://www.kyland.com>