

KOM600G Fiber Media Converter

Hardware Installation Manual

Publish Date: June, 2022

Version: V1.0

KYLAND

Disclaimer: Kyland Technology Co., Ltd. tries to keep the content of this manual as accurate and as updated as possible. This document is not guaranteed to be error-free, and we reserve the right to amend it without notice to users.

All rights reserved.

No part of this documentation may be excerpted, reproduced, translated, annotated or duplicated, in any form or by any means without the prior written permission of Kyland Corporation.

Copyright © 2022 Kyland Technology Co., Ltd.

Notice for Safety Operation

The product performs reliably as long as it is used according to the guidance. Artificial damage or destruction of the device should be avoided. Before using the device, read this notice carefully for personal and equipment safety. Please keep the manual for further reference. If the device used not according to the specified way by Kyland, the protection provided by the device maybe diminished. And Kyland is not liable to any personal or equipment damage caused by violation of this notice.

- Ensure the area where the device is used is clean and dry. Keep the ambient relative humidity within the range from 5% to 95% (non-condensing). Be suitable for indoor use.
- Do not place the device in an environment with high magnetic field, strong shock, or high temperature. Keep the working and storage temperatures within the allowed range.
- Install and place the device securely and firmly.
- Please keep the device clean; if necessary, wipe it with a soft cotton cloth.
- Do not place any irrelevant materials on the device or cables. Ensure adequate heat dissipation and tidy cable layout without being entangled or knotted.
- Wear antistatic gloves or take other protective measures when operating the device.
- Avoid any exposed metal wires because they may be oxidized or electrified.
- Install the device in accordance with related national and local regulations.
- Before power-on, make sure the power supply is within the allowed range of the device. High voltage may damage the device.
- Power connectors and other connectors should be firmly interconnected.
- Do not plug in or out the power supply with wet hands. When the device is powered on, do not touch the device or any parts with wet hands.
- Before operating a device connected to a power cable, remove all jewelry (such as rings, bracelets, watches, and necklaces) or any other metal objects, because they may cause electric shock, burns, or welding.
- Do not operate the device or connect or disconnect cables during an electrical storm.
- Use compatible connectors and cables. If you are not sure, contact our sales or technical

support personnel for confirmation.

- Do not disassemble the device by yourself. When an anomaly occurs, contact our sales or technical support personnel.
- If any part is lost, contact our sales or technical support personnel to purchase a replacement. Do not purchase parts from other channels.
- Dispose of the device in accordance with relevant national provisions, preventing environmental pollution.
- Note: The security of any system merged with this device is the responsibility of the assembler.

In the following cases, please immediately shut down your power supply and contact your Kyland representative:

- Water gets into the equipment.
- Equipment damage or shell damage.
- Equipment operation or performance has abnormally changed.
- The equipment emits odor, smoke or abnormal noise.

Contents

1 Product Overview	1
2 Structure and Interface	2
2.1 Front Panel	2
2.2 Top Panel.....	3
3 Mounting.....	4
3.1 Dimension Drawing.....	4
3.2 Mounting Mode and Step	4
3.2.1 DIN-Rail Mounting	5
3.2.2 DIN-Rail Dismounting	5
4 Connection	7
4.1 10/100/1000Base-T(X) Ethernet Port.....	7
4.2 100/1000Base-X, 10/100/1000Base-T(X) SFP slot.....	8
4.2.1 SFP Optical Module.....	9
4.2.2 SFP Electrical Module	10
4.3 Grounding	10
4.4 Power Terminal Block	11
5 LFP	13
6 LEDs.....	14
7 Basic Features and Specifications.....	15

1 Product Overview

KOM600G is a green industrial fiber media converter with low power consumption. It is applicable to wind power, distribution network automation, subway PIS, power SACDA, sewage treatment, expressway, metallurgy, intelligent transportation, and many other industries. KOM600G supports the Link Fault Pass-Through (LFP) function, which facilitates fault locating and network maintenance.

KOM600G provides one 1000Base-X, 10/100/1000Base-T(X) SFP slot (namely, Gigabit SFP slot), and one 10/100/1000Base-T(X) Ethernet port. For details, see the following table.

Table 1 KOM600G Model

Product Model	KOM600G -Ports - PS1- PS2
Code Definition	Code Option
Ports	1GX1GE
	Description: 1GX1GE: <i>one 1000Base-X ,SFP port; one 10/100/1000Base-T(X) Copper Port</i>
PS1-PS2: Power Input	LV-LV (24VAC/DC (18-30VAC, 50/60Hz; 12-48VDC), Redundancy input)



Note:

We reserve the right to amend the product information listed in this table without notice. To obtain the latest information, you can contact our sales or technical support personnel.

2 Structure and Interface



Caution:

It is recommended to purchase the port dustproof shield (optional) to keep ports clean and ensure switch performance.

2.1 Front Panel

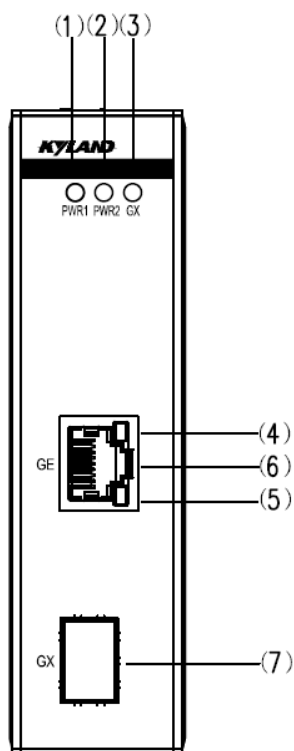

Figure 1 Front Panel

- (1) Power 1 LED (2) Power 2 LED (3) Gigabit SFP interface indicator
- (4) 10/100/1000Base-T(X) Ethernet port speed LED (yellow)
- (5) 10/100/1000Base-T(X) Ethernet Port connection status LED (green)
- (6) 10/100/1000Base-T(X) Ethernet Port
- (7) 1000Base-X SFP slot

2.2 Top Panel

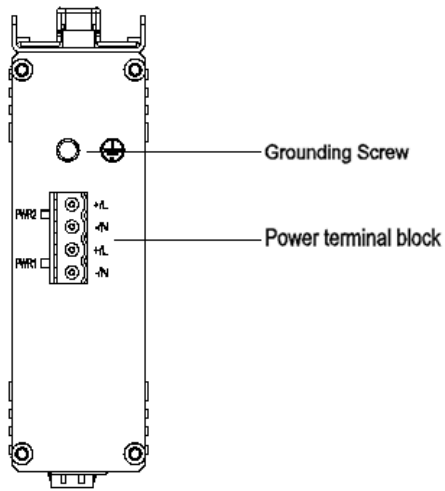

Figure 2 Top Panel

3 Mounting

3.1 Dimension Drawing

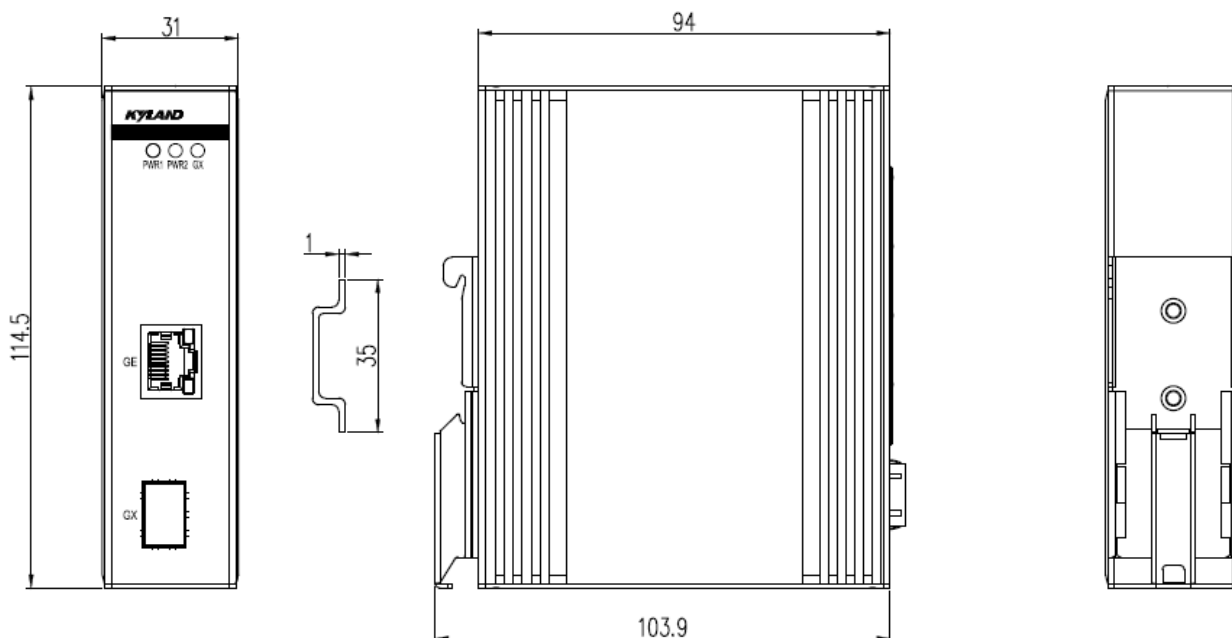

Figure 3 Opal5GL Dimensions for DIN-Rail Mounting (unit: mm)



Caution:

- As part of the heat dissipation system, the switch housing becomes hot during operation. Please use caution when coming in contact and avoid covering the switch housing when the switch is running.
- The figures in this manual are only for reference

3.2 Mounting Mode and Step

The device supports DIN-rail mounting. Before installation, please confirm the following installation requirements:

- 1) Environment: Operating temperature $-40^{\circ}\text{C} \sim +75^{\circ}\text{C}$, Ambient Relative Humidity: 5-95% (non-condensing)
- 2) Power: Verify that the operating voltage matches the voltage range marked on the device

- 3) Ground Resistance: $<5\Omega$.
- 4) Avoid direct sunlight, away from heat sources or areas with strong electromagnetic interference
- 5) Devices are to be installed in an ATEX /IECEX Certified IP54 enclosure and accessible only by the use of a tool.

3.2.1 DIN-Rail Mounting

Step 1: Select the mounting position for the device and guarantee adequate space and heat dissipation.

Step 2: Insert the sheet metal connecting seat onto the top of the DIN rail, and push the bottom of the device inward and upward to ensure the DIN rail fits in the connecting seat. Make sure the device is firmly installed on the DIN rail, as shown in the following figure.

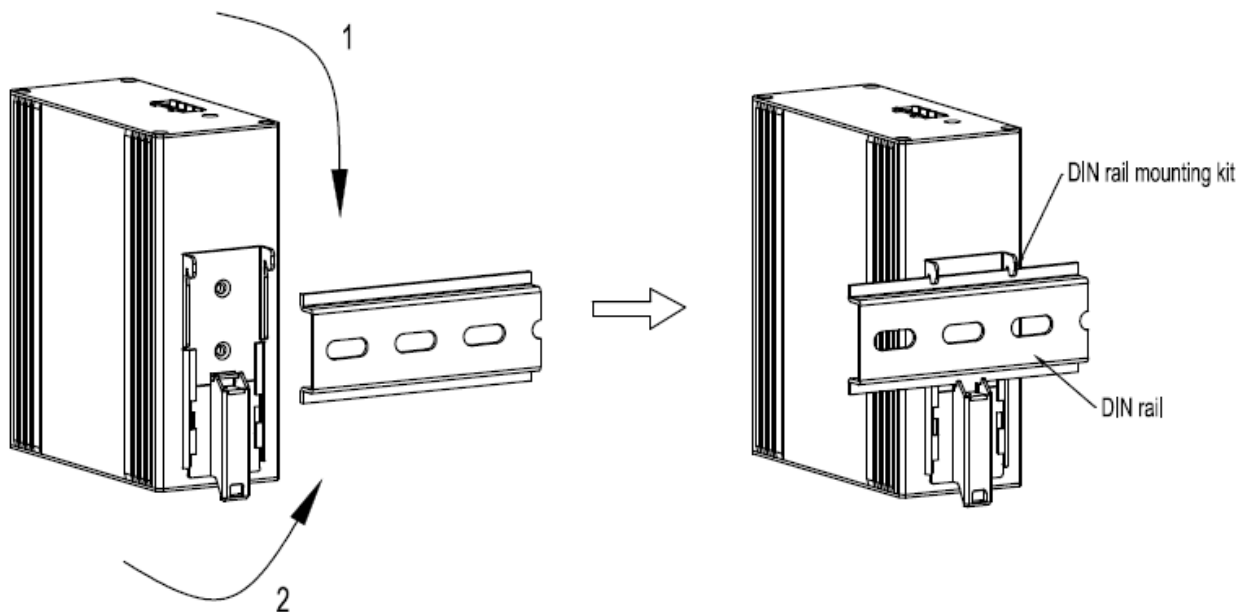

Figure 4 Sheet Metal DIN-Rail Mounting

3.2.2 DIN-Rail Dismounting

Step 1: As shown in the following figure, press the device downward and move the device in direction 1 until the bottom of the device is detached from the DIN rail.

Step 2: Pull the device upward and move the device in direction 2 until the device is

removed from the DIN rail completely.

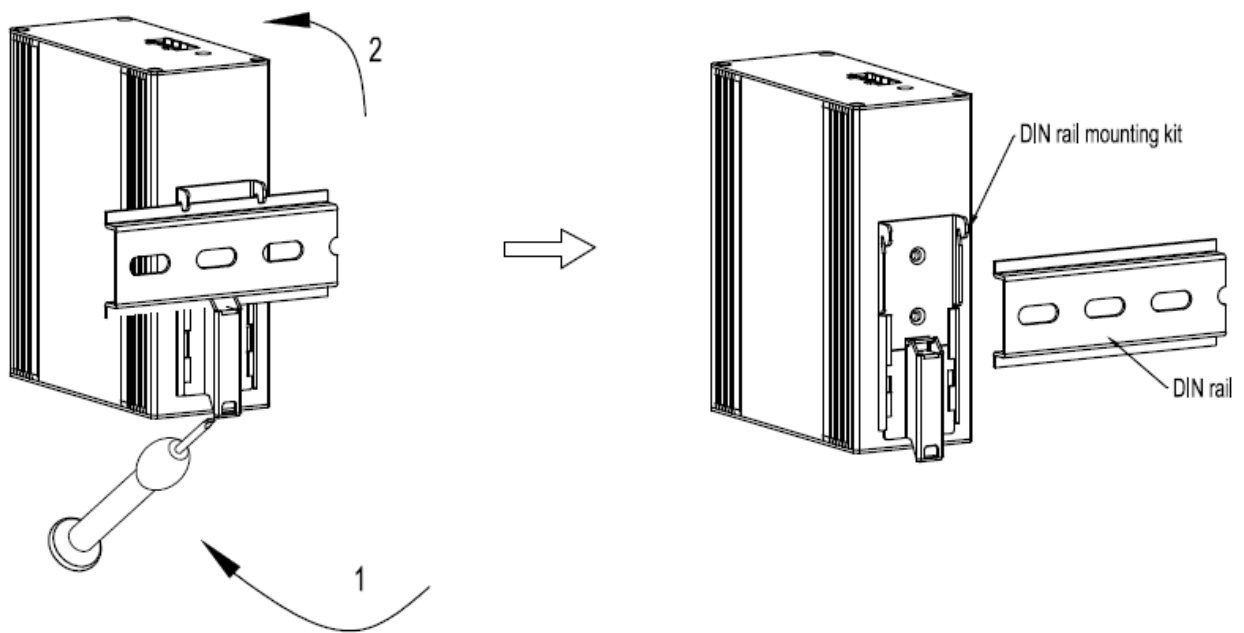

Figure 5 Sheet Metal DIN Rail Dismounting

4 Connection

4.1 10/100/1000Base-T(X) Ethernet Port

10/100/1000Base-T(X) Ethernet port is equipped with RJ45 connector. The port is self-adaptive. It can automatically configure itself to work in 10M, 100M, or 1000M state, full or half duplex mode. The port can also adapt to MDI or MDI-X connection automatically. You can connect the port to a terminal or network device with a straight-through or cross-over cable.

- Pin Definition

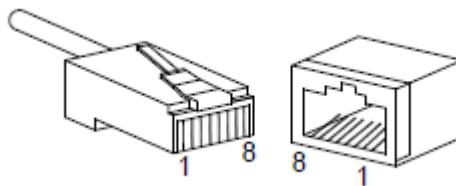

Figure 6 RJ45 Port

Table 2 Pin Definitions of 10/100Base-T(X) RJ45 Port

Pin	MDI-X	MDI
1	Transmit/Receive Data (TRD1+)	Transmit/Receive Data (TRD0+)
2	Transmit/Receive Data (TRD1-)	Transmit/Receive Data (TRD0-)
3	Transmit/Receive Data (TRD0+)	Transmit/Receive Data (TRD1+)
4	Transmit/Receive Data (TRD3+)	Transmit/Receive Data (TRD2+)
5	Transmit/Receive Data (TRD3-)	Transmit/Receive Data (TRD2-)
6	Transmit/Receive Data (TRD0-)	Transmit/Receive Data (TRD1-)
7	Transmit/Receive Data (TRD2+)	Transmit/Receive Data (TRD3+)
8	Transmit/Receive Data (TRD2-)	Transmit/Receive Data (TRD3-)



Note:

"+" and "-" indicate level polarities.

- Wiring Sequence

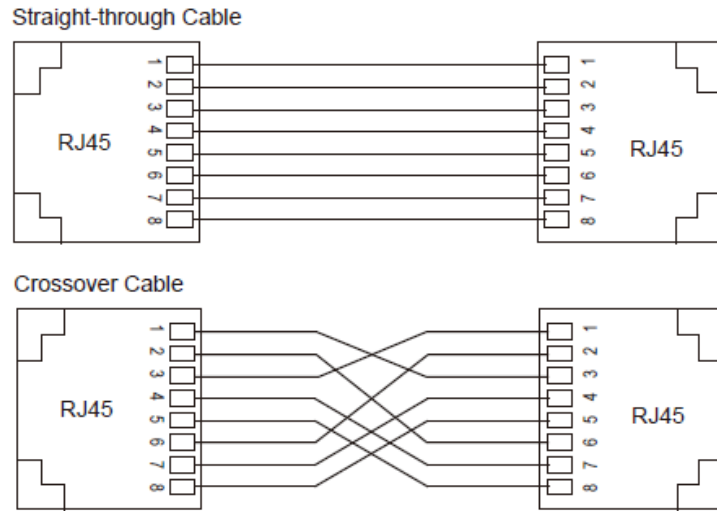

Figure 7 Connection Using Straight-through/Cross-over Cable



Note:

The color of the cable for RJ45 connector meets the 568B standard: 1-orange and white, 2-orange, 3-green and white, 4-blue, 5-blue and white, 6-green, 7-brown and white, and 8-brown.

4.2 100/1000Base-X, 10/100/1000Base-T(X) SFP slot

100/1000Base-X, 10/100/1000Base-T(X) SFP slot (gigabit SFP slot) requires an SFP optical/electrical module to enable data transmission. The following table lists the SFP optical/electrical modules (optional) supported by the series switches.

Table 3 SFP Optical/Electrical Modules

Model	Port	MM/SM	Connector	Central Wavelength	Transmission Distance
IGSFP-M-SX-LC-850-0.55	1000Base-X port	MM	LC	850nm	0.55km
IGSFP-S-LX-LC-1310-10	1000Base-X port	SM	LC	1310nm	10km
IGSFP-S-LH-LC-1310-40	1000Base-X port	SM	LC	1310nm	40km
IGSFP-S-ZX-LC-1550-80	1000Base-X port	SM	LC	1550nm	80km
IG-FSFP-M-LX-LC-1310-2	100Base-FX port	MM	LC	1310nm	2km
IG-FSFP-S-LX-LC-1310-10	100Base-FX port	SM	LC	1310nm	10km
IGSFP-10/100/1000BASE-T-RJ45	10/100/1000Base-T(X) port	--	RJ45	--	--



Note:

The device uses the SFP module that supports digital diagnosis to support the optical power detection function of the SFP slot. For details about the SFP module, consult our sales or technical support personnel.

4.2.1 SFP Optical Module

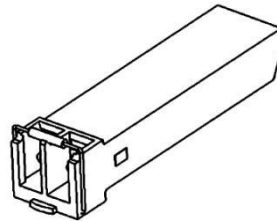

Figure 8 SFP Optical Module

An SFP optical module is equipped with LC connector, and each port consists of a TX (transmit) port and an RX (receive) port. To enable communication between Device A and Device B, connect the TX port of Device A to the RX port of Device B, and the RX port of Device A to the TX port of Device B, as shown in the following figure.

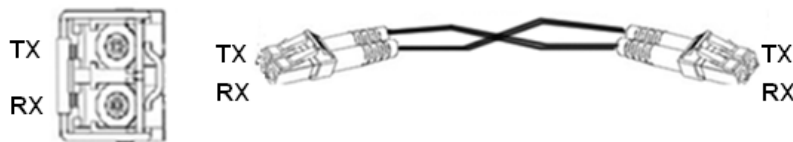

Figure 9 Fiber Connection of an SFP Optical Module

- How to Connect the SFP Optical Module

Insert the SFP optical module into the SFP slot in the switch, and then insert the fibers into the TX port and RX port of the SFP module.

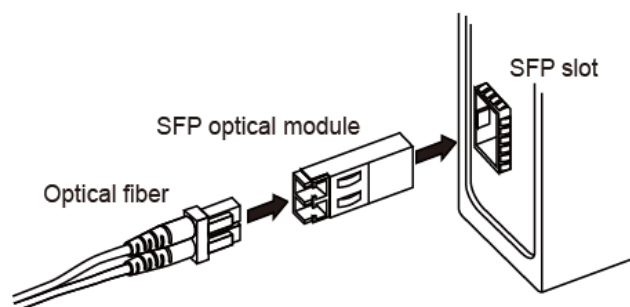

Figure 10 Connecting the SFP Optical Module

Identify the RX port and TX port of an SFP optical module:

1. Insert the two connectors in one end of two fibers into the SFP module, and those in the other end into the peer module.
2. View the corresponding connection status LED:

If the LED is on, the connection is correct. If the LED is off, the link is not connected. This may be caused by incorrect connection of the TX and RX ports. In this case, swap the two connectors at one end of the fibers.



Caution:

- The device uses laser to transmit signals in fibers. The laser meets the requirements of level 1 laser products. Routine operation is not harmful to your eyes, but do not look directly at the fiber port when the device is powered on.
- If the defined transmission distance of an SFP module is longer than 60km, do not use a short fiber (<20km) for connection. If such a short fiber is used, the module will be burned.

4.2.2 SFP Electrical Module

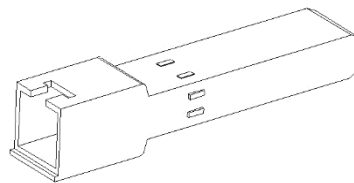

Figure 11 SFP Electrical Module

- How to Connect the SFP Electrical Module

Insert the SFP electrical module into the SFP slot in the switch, and then insert the RJ45 connector of the twisted pair into the SFP module.

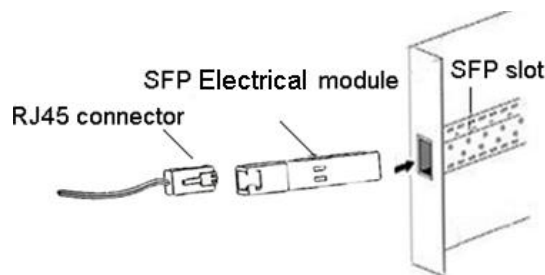

Figure 12 Connecting the SFP Electrical Module

4.3 Grounding

Grounding protects the device from lightning and interference. Therefore, you must ground the

device properly. You need to ground the device before it is powered on and disconnect the grounding cable after the device is powered off.

There is a grounding screw (see Figure 2) on the top panel of the switch. The screw is for chassis grounding. After crimping one end of the grounding cable to a cold pressed terminal, secure the end of the grounding cable to the grounding screw and firmly connect the other end to ground.



Note:

Cross-sectional area of the chassis grounding cable >2.5mm²; Grounding resistance <5Ω.

4.4 Power Terminal Block

There is a power terminal block on the top panel of the device. You need to connect the power wires to the terminal block to provide power for the device. The switch supports redundant power supply with 4-pin 5.08mm-spacing plug-in terminal block. When one power input is faulty, the switch can continue operating properly, thereby improving network reliability.



Note:

Use copper conductors only, temperature rating 85.5°C only.

- 4-Pin 5.08mm-Spacing Plug-in Terminal Block

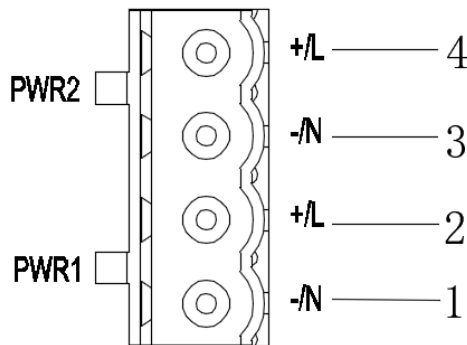

Figure 13 4-Pin 5.08mm-Spacing Plug-in Terminal Block (socket)

Table 4 Pin Definitions of 4-Pin 5.08mm-Spacing Plug-in Terminal Block

Pin Number	DC Wiring Definition	AC Wiring Definition
1	PWR1: -	PWR1: N
2	PWR1: +	PWR1: L
3	PWR2: -	PWR2: N

4	PWR2: +	PWR2: L
---	---------	---------

● **Wiring and Mounting**

Step 1: Ground the device properly according to section 4.3.

Step 2: Remove the power terminal block from the device.

Step 3: Insert the power wires into the power terminal block according to Table 4 and secure the wires.

Step 4: Insert the terminal block with the connected wires into the terminal block socket on the device.

Step 5: Connect one end of the power cable to an external power supply system (with the allowed power range). If the power LED on the front panel of the switch turns on, the power supply is connected properly.

Wiring and mounting should meet following specifications.

Table 5 Wiring and Mounting Specifications

Terminal Type	Required Torque	Wire Range (AWG)
Terminal Block Plug	4.5-5.0 lb-in	12-24



Caution:

- Provision shall be made to prevent the rated voltage from being exceeded by transient disturbances of more than 140% of the rated voltage.
- Power adapter provide by end customer shall be non-sparking.
- Before connecting the device to power supply, make sure that the power input meets the power requirement. If connected to an incorrect power input, the device may be damaged.
- To comply with UL restrictions, this equipment must be powered from a source compliant with SELV.



Warning:

- Do not touch any exposed conducting wire, terminal, or component with a voltage warning sign, because it may cause personal injury.
- Do not remove any part or plug in or out any connector when the device is powered on.

5 LFP

The LFP function is used to detect the working status of remote devices. If a remote device is faulty, the status of all ports in the link changes to link-down through LFP packet exchange, so that the local device can detect a fault rapidly.

As shown in the following figure, if the connection between the client and fiber media converter B is faulty, fiber media converter B shuts down port B1 upon detecting the fault. Upon detecting that the connection of port A1 is faulty, fiber media converter A shuts down port A1 and port A2. As a result, the server connected to port A2 detects the fault between the client and port B2 rapidly.

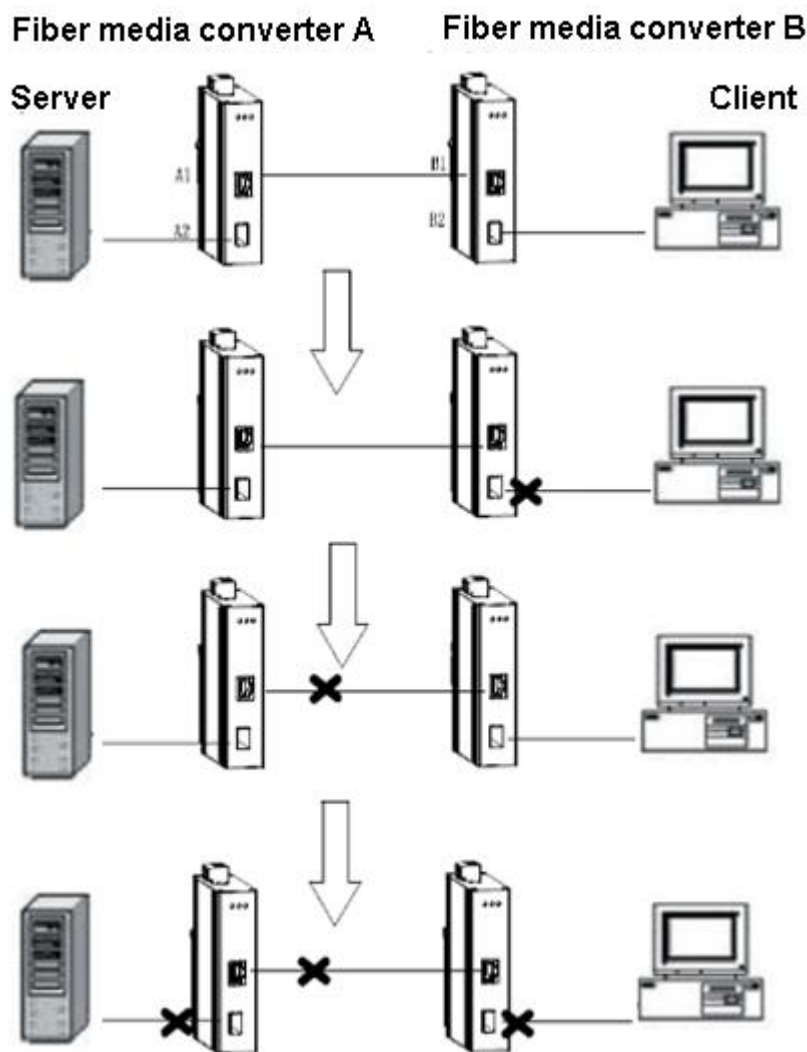

Figure 14 LFP



Caution:

The LFP function is available only when both the connected devices support the function.

6 LEDs

Table 6 LED Description

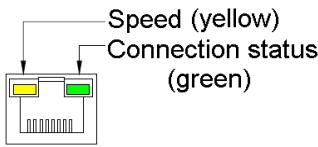
LED	State	Description
Power 1 LED	On	The power 1 is connected and operates properly.
	Off	The power 1 is not connected or operates abnormally.
Power 2 LED	On	The power 2 is connected and operates properly.
	Off	The power 2 is not connected or operates abnormally.
Gigabit SFP slot connection status LED	On	Effective port connection
	Blinking	Ongoing network activities
	Off	No effective port connection
		
10/100/1000Base-T(X) Ethernet port speed LED (yellow)	On	1000M working state (1000Base-TX)
	Off	10/100M working state (10/100Base-T(X)) or no connection
10/100/1000Base-T(X) Ethernet port connection status LED (green)	On	Effective port connection
	Blinking	Ongoing network activities
	Off	No effective port connection

7 Basic Features and Specifications

Power Supply		
Power Identifier	Rated Voltage Range	Maximum Voltage Range
LV	24VAC/DC(18-30VAC/12-48VDC)	18-30VAC/9-60VDC
Terminal Block	4-Pin 5.08mm-Spacing Plug-in Terminal Block	
Rated Power Consumption		
Rated Power Consumption	2.5W (MAX)	
Physical Characteristics		
Housing	Metal, fanless	
Installation	DIN-Rail Mounting	
Dimensions(W×H×D)	31mm×114.5mm×94mm (excluding connectors, DIN rail)	
Weight:	0.3Kg	
Environmental Limits		
Ambient Temperature	-40°C ~ +75°C	
Storage Temperature	-40°C ~ +85°C	
Ambient Relative Humidity	5% ~ 95% (no condensing)	
MTBF		
MTBF	8762929h	
Warranty		
Warranty	Five years	

KYLAND

FAX: +86-10-88796678

Website: <http://www.kyland.com>

Email: support@kyland.com

For more information about KYLAND
products, please visit our website:

<http://www.kyland.com>